

Investigation of the MIFIS Concept for Enhanced Flame Stability and Blowout Recovery

L. P. Antoniou*, K. Stavridis, M. T. Papadopoulos

* Department of Aerospace Engineering, National Technical University of Athens, Greece
Institute of Structural Mechanics, RWTH Aachen University, Germany

ABSTRACT

In the present work, a method for the prompt and remediation of offshore Blowouts and seabed hydrates' intervention is presented. The method is a modified version of DIFIS System, an EU FP6 proposed solution for the oil recovery from tankers wreck. It relies on gravity to channel the blow-out mixture towards the surface. Two (2) components are used for the oil/water/gas separation (PG-BBS) and oil/water storage (BB). These components are placed a 300 m and 30 meters below the sea surface respectively, unaffected by the weather conditions. This is achieved by a quickly deployable flexible structure (MIFIS) that should stay in place until the well is emptied or appropriate sealed in order to eliminate the pollution threat. The PG-BBS and BB reservoirs are provided with standard equipment through which shuttle vessels can recover the oil and gas rapidly, using standard offshore/subsea equipment. As an innovative system, the principal investigation (operational environment, system components' description, structural requirements/specifications, design guidelines) was carried out. The parameters were used for the Technical Feasibility study where the concept was evaluated. The final results can be used for the implementation of new innovative research projects and solutions in Offshore/Subsea industry.

KEYWORDS: Hydrates, DIFIS, Blow-out, deep sea operation, pollution intervention.

INTRODUCTION

The offshore oil rig operations in deepwater ocean led to major accidents during the last fifty (50) years. The most notable accidents are: Union Oil Platform Alpha Well A-21 (1969), Ekofisk Bravo Platform (1977), Sedco 135F and the IXTOC-1 Well (1979), Funiwa No. 5 Well (1980), Hasbah Platform Well 6 (1980) and Deepwater Horizon (2010). More than four (4) million barrels of oil were released to the ocean, causing extreme water pollution to the regions and killing the working staff on the platform.

At the recent accident of the Deep water Horizon (2010), during the final phases of drilling the exploratory well at Macondo, a geyser of seawater erupted from the marine riser onto the rig, shooting 240 ft (73 m) into the air. This was soon followed by the eruption of a slushy combination of mud, methane gas, and water. The gas component of the slushy material quickly transitioned into a fully gaseous state and then ignited into a series of explosions and then a firestorm. An attempt was made to activate the blowout preventer, but it failed. The final defense to prevent an oil spill, a device known as a blind shear ram, was activated but failed to plug the well. At the time of the explosion, there were 126 crew on board. Eleven workers were presumed killed in the initial explosion. The rig was evacuated, with injured workers airlifted to medical facilities. After 36 hours, Deepwater Horizon sank on 22 April 2010. The rig remains were located resting on the seafloor approximately 5,000 ft (1,500 m) deep at that location, and about 1,300 ft (400 m) (quarter of a mile) northwest of the well. (Wikipedia, 2010) The resultant oil spill continued until 15 July when it was closed by a cap. This involved placing a 125-tonne (276,000 lb) dome over the largest of the well leaks and piping it to a storage vessel on the surface. This option had the potential to collect some 85% of the leaking oil but was previously untested at such depths. BP deployed the system on May 7–8, but it failed due to buildup of methane clathrate inside the dome; with its low density of approximately 0.9 g/cm³ the methane hydrates accumulated in the dome, adding buoyancy and obstructing flow. Relief valves were used to permanently seal the well, which was declared "effectively dead" on 19 September 2010. BP was forced to spend more than 20 billion dollars to pay the claims to Federal Government and to clean up the oil spill, leading the company to a manageable sum for the next 15 years.

In the aftermath of the Deepwater Horizon disaster, an innovative concept for the direct intervention at the blowout well was introduced by the JRC following the experience by the EU FP6 DIFIS Project [REFF]. The principal investigation and the feasibility study of this concept were assigned to Scientific Laboratories in Greece in order to prove the sustainability of the proposed solution. The results of this work were the operational limits and the structural requirements of the MIFIS System which can be implemented to deal with Offshore Blowouts and Hydrate intervention.

OPERATIONAL ENVIRONMENT

A blowout is the uncontrolled release of crude oil and/or natural gas from an oil well or gas well after pressure control systems have failed. Prior to the advent of pressure control equipment in the 1920s, the uncontrolled

release of oil and gas from a well while drilling was common and was known as an oil gusher, gusher or wild well. An accidental spark during a blowout can lead to a catastrophic oil or gas fire (Holand, 1997).

Nowadays (2015), it is very difficult to deal with a blowout in very deep water because of the remoteness and limited experience with this type of situation (Figure 1).

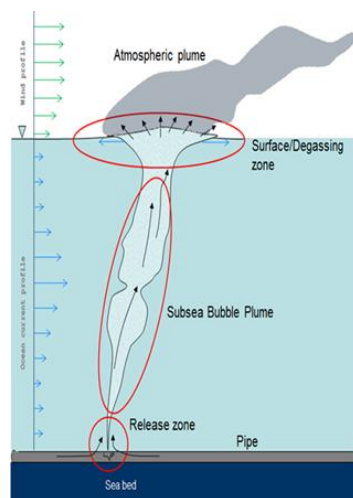

Figure 1: Gas Blowout for low pressure and high temperature conditions

At sufficient depths, methane complexes directly with water to form methane hydrates, as was observed during the Deepwater Horizon oil spill in 2010. Methane clathrate ($\text{CH}_4 \cdot 5.75\text{H}_2\text{O}$), also called methane hydrates, is a solid clathrate compound (more specifically, a clathrate hydrate) in which a large amount of methane is trapped within a crystal structure of water, forming a solid similar to ice (Bollavaram, 2002; Demirbas, 2010; Hardage and Roberts, 2006; Huo et al., 2011; Sloan and Koh, 2008). The equilibrium of the methane hydrate solid compound is depended on sea depth (hydrostatic pressure) and sea temperature. As the hydrostatic pressure decreases and temperature increases reaching the sea surface, the hydrates rapidly decompose realizing the gas. The gas further expands its volume leading to a surface/degassing zone. This zone contacts the atmospheric air changing the environmental conditions (Devinder et al., 2007; Mazarakos and Kostopoulos Part 1, 2015).

The hydrates behavior can be predicted using Phase Diagrams of gas-hydrates. These are calculated using van der Waals and Platteeuw's model with a Kihara spherical-core potential for the interaction between water and the guest molecule (Lundgaard and Mollerup, 1992).

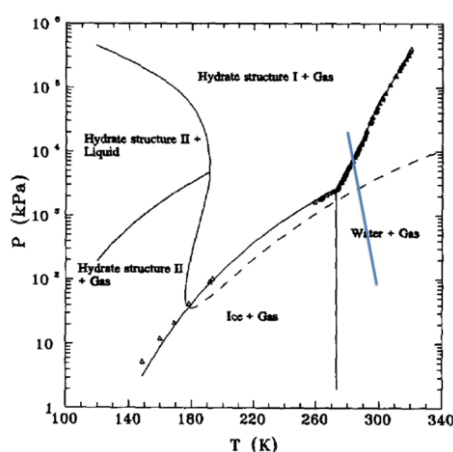

Figure 2: Hydrates' phase diagram depending on Pressure and Temperature

The blue line in Figure 2 illustrates the pressure & temperature limits for a sea depth of 2000 meters in conjunction with the methane hydrate phase diagram. The maximum pressure ($2\text{E}+04$ kPa) and low temperature zone (275K) is corresponding to the seabed (2000 meters) and the minimum pressure (100kPa) and high temperature (300K) zone is corresponding to the sea surface (Figure 2). These limits are expressed to the sea depth in order to specify the threshold point and the decomposition depth of the methane hydrates.

The decomposition's depth estimation is important in order to specify the position of the MIFIS System's components. The hydrate solid compounds can lead to "Plug Blockage" in pipes, risers and valves. This condition is insufficient and dangerous for the Subsea Equipment. To prevent plug, additional inhibitors have to be included such as methanol, heat or salt solutions. These parameters are important for each subsystem's mass, inertia, cost and operation.

THE MIFIS CONCEPT-A MODIFIED DIFIS SYSTEM

DIFIS is a system for a prompt underwater intervention on deep shipwrecks, conceived at JRC soon after the PRESTIGE accident. It relies on gravity forces to collect the leaking mix (water and oil) by means of a large fabric dome solidly anchored around the wreck and channel it through a large (typically Ø 2m) riser tube towards the sea surface. However, instead of recovering the oil directly at the surface (resulting in a system sensitive to adverse surface weather conditions), the flow of oil water mix is channeled to a large bell shaped buffer/separator reservoir, 30 m below the sea surface, where the oil occupies the upper part while the water escapes from the open bottom. The Buffer Bell, through its buoyancy, keeps the whole system in tension. A shuttle tanker, provided with standard offshore equipment, periodically empties the buffer bell according to the leakage rates and the weather conditions. A strong anchoring system keeps the whole system anchored to the seabed (Figure 3).

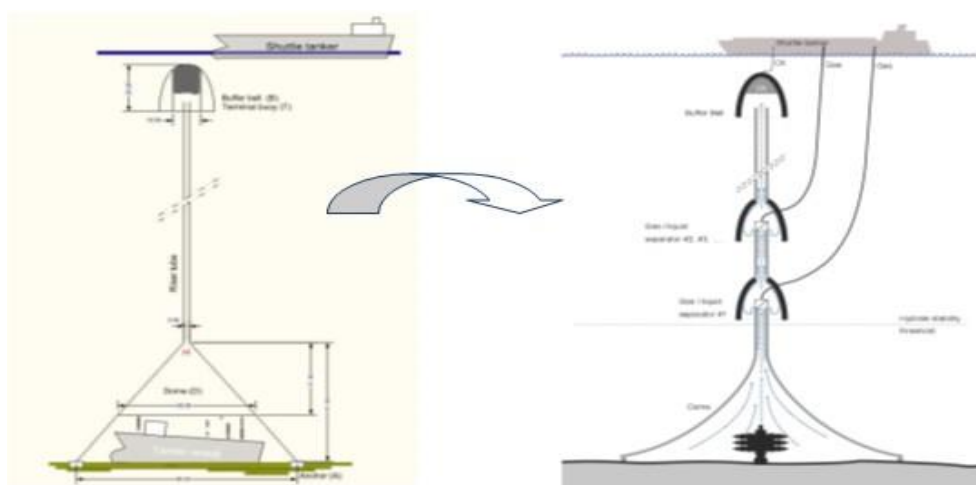

Figure 3: The DIFIS System (left) for oil recovery in comparison with the MIFIS Concept (right)

MIFIS is a modular modification of DIFIS System, concerning the handling of the gas and the hydrates. In MIFIS, the water-oil-gas-hydrate mixture collected in the funnel, shaped dome, instead of being channeled directly to the Buffer Bell, passes through a cascade of bell-shaped gas separators that extract whatever gas is present or is generated from the hydrate dissociation, before it can accumulate speed and cause stability problems. The number, placement and capacity of the bell-shaped gas separators depend on the expected quantities of gas, oil and hydrates and on the environmental conditions (Andritsos and Cozijn, 2011).

THE MIFIS POC DESIGN PROCESS

For the deepwater operations (Mazarakos and Kostopoulos Part 2, 2015), the MIFIS PoC design process introduces 9 main components: 1) the Buffer Bell (BB) (1) for oil/water temporarily storage, 2) the Upper Riser tube (RTCu) (2), parts of riser tubes where the oil/water mixture is guided to BB from the LGS, 3) the Lower Riser tube (RTCl) (2), parts of riser tubes where the oil/water/gas/hydrates are guided to LGS/PG-BBS from the Dome 4) the stiffening rings (SR) (3), a similar to DIFIS structure which connects the RTC upper and the RTC lower parts with the mooring system, 5) the Liquid/Gas Separator (LGS/PG-BBS) (4) where the liquid (oil/water) will be separated from the gas, 5) the Dome Interface Unit, (DIU) (5) a similar to DIFIS structure that connects the dome with RTCl, 6) the dome (D) (6) a flexible conical cloth, that covers the well and guides the mixture to the RTCl, 7) the Mooring/Anchoring System (ML/AS) (7), which support the RT column running through their periphery, transfers the components' hydrodynamic/inertia loads to the anchoring system at the seabed, and 8) the heating/inhibitor device (HID) (8), located on the SR structure that which prevent the RTCl parts' blockage by the hydrate agglomeration and plugging. The components are presented in Figure 4.

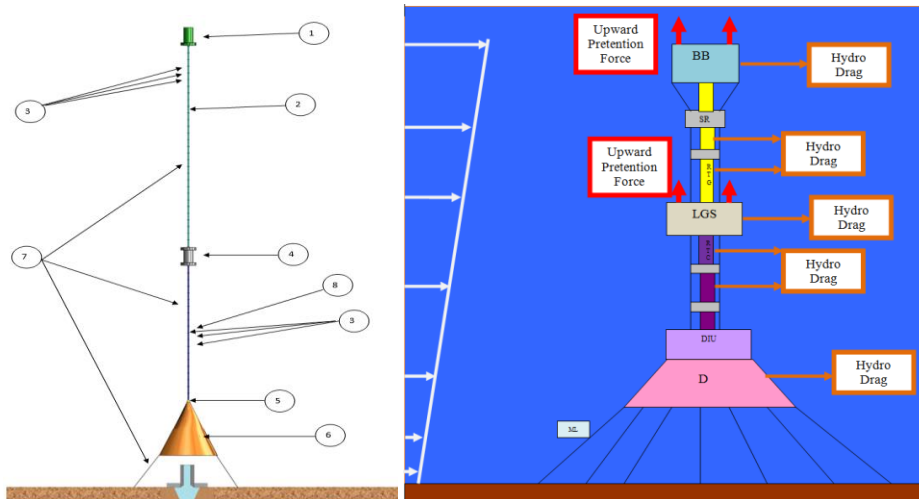

Figure 4: MIFIS components location at the operational phase (left) and the hydrodynamic loads on the MIFIS structure (right)

The Proof of Concept (PoC) design process is based on the previous experience of the DIFIS System. The DIFIS parametric preliminary and the detailed calculations were extrapolated in order to include the mass and inertia changes for the MIFIS loads' estimations (Figure 5).

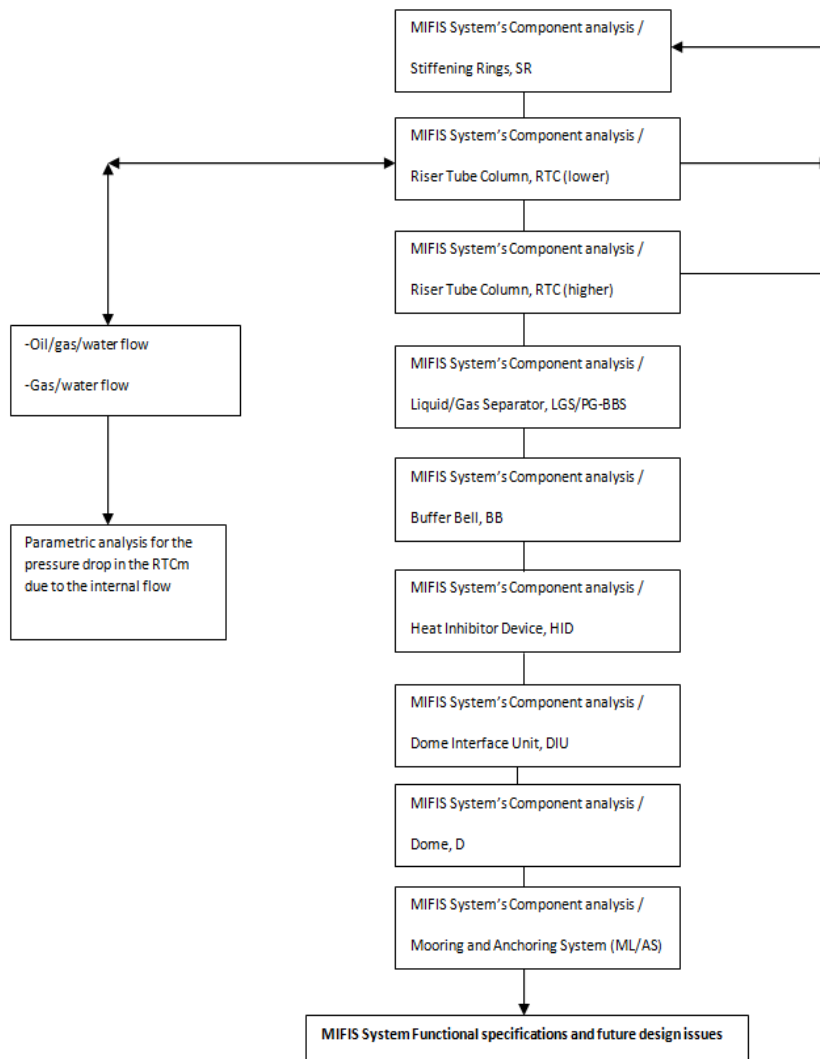

Figure 5: MIFIS System proof of concept design process

PULMONOLOGY

The PoC methodology was introduced during the DIFIS System design and testing process. It was fully proposed as a PhD Design Methodology and Evaluation process (Mazarakos, 2012). The methodology includes a full parametric-loop process using the dimensions of each component. Selecting the main dimensions, the material and the applied load, the mass/inertia and buoyancy force are estimated. The estimation is based on a preliminary design calculation tool (MATLAB numerical code) and CFD/FEA modeling, developed for the DIFIS System (Mazarakos et al, 2012). These analyses (Mazarakos and Kostopoulos Part 2, 2015), include parametric structural considerations (tensile strength) as a function of the component's mass/inertia (material selection & dimensions), the applied load (differential pressure, buckling force, bending moments etc), and the buoyancy (displaced volume). This procedure is presented in Figure 6.



Figure 6: MIFIS Concept PoC methodology

The final outcomes from these analyses are the dimensions and the mass properties of each component based on the applied loads. These output results are used for the structural requirements specifications and the Feasibility analysis study (Mazarakos and Kostopoulos Part 3, 2015).

MIFIS COMPONENTS STRUCTURAL REQUIREMENTS/SPECIFICATIONS

The MIFIS's structural requirements are used for the functional specifications of each component. The proposed design guidelines are procedures that connect the preliminary design with the detail design. For each of the components, the structural limits are presented regarding the PoC methodology.

Buffer Bell Structural Requirements

The Buffer Bell (BB) is located at the top of the structure and it is filled with oil and seawater coming from the LGS/PG-BBS and passing through the upper RTC (Figure 7). The BB selection is based on the capacitor's volume and the floater's buoyancy (Table 1). The parametric analysis combines the structural integrity with the applied pressure and the component's weight/buoyancy balance force.

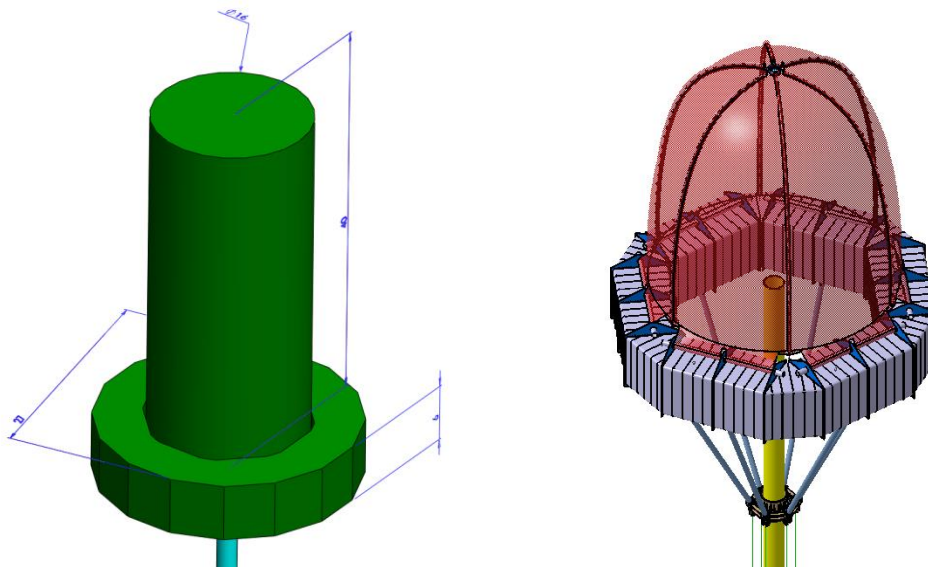

Figure 7: MIFIS concept BB conceptual view (left) and DIFIS System BB (right) detailed view

Table 1: MIFIS Concept's Buffer Bell (BB) Design Structural Requirements.

BB Structural Requirements	
Maximum capacitor's volume (m ³)	5800
Dimensions	Diameter: 12 meters Length: 52 meters
Maximum floater's buoyancy (tons)	3000
Material properties	Steel structure or GFRP
Mass in air (tons)	Not exceeding 900 tons
Chemical corrosion resistance	Seawater (>35 ppt)
Minimum depth position (m)	30 meters below the sea surface
Operational Temperature	20°C
Structural loads	-Floater: Hydrostatic pressure of 70 meters (7 bars) - Capacitor: Dynamic pressure due to sea currents velocity (0.7 m/s)

Comparing to DIFIS System, the MIFIS's BB is the same. Furthermore, the weight optimization can be achieved using Finite Element analysis following the DIFIS System Design and Development procedure.

Riser Tube Structural Requirements

The RTC connects the LGS/PG-BBS with the DIU (lower part) and the LGS/PG-BBS with BB (upper part). It also transfers the multiphase mixture from Dome to LGS and oil/water from LGS to BB (Figure 8). The RTC is stressed by the sea currents' dynamic pressure load. Using the Flow calculations analysis the multiphase mixture does not affect the internal pressure. Thus, the differential pressure neglected, similar to DIFIS System. For structural reasons, only for the lower part, a qualification burst pressure of 5 bars was set, due to the oil/gas/hydrate internal flow (Table 2).

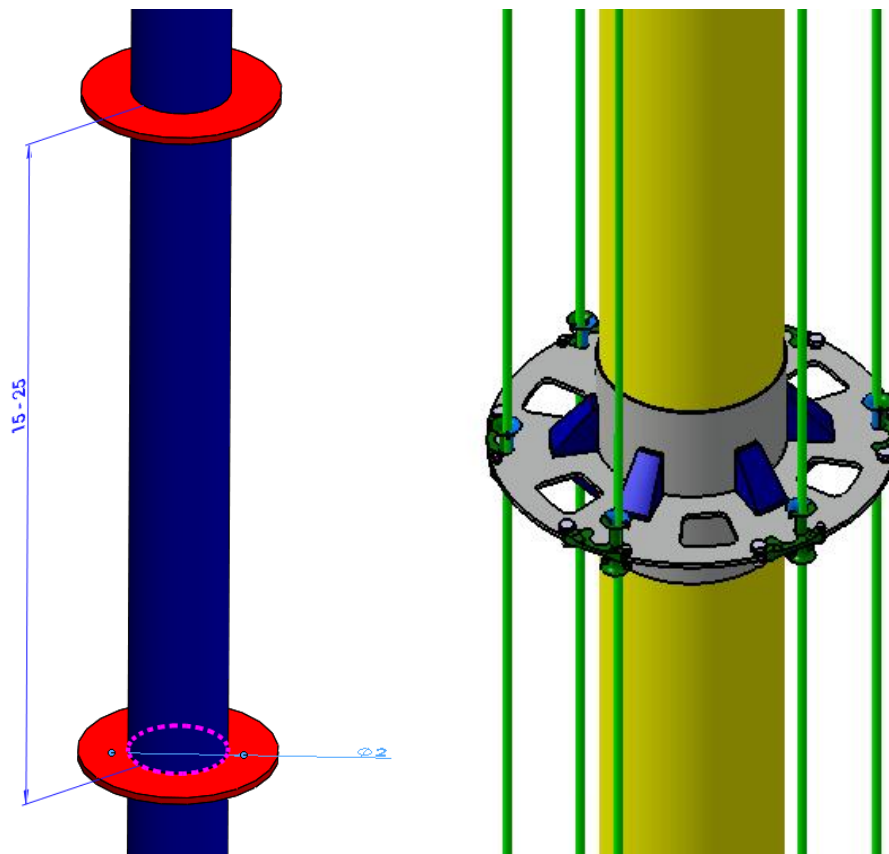

Figure 8: MIFIS Concept Riser Tube Column part (left) and DIFIS System Detailed design part (right)

Table 2: MIFIS Concept Riser Tube Column mixture (RTC) Design Structural Requirements.

RTC Structural Requirements	
Material properties	GFRP , CFRP or PE
Wall thickness (mm)	> 200 mm for PE > 2.5mm for GFRP,CFRP
Maximum length (m)	25
Mass in air (tons)	Not exceeding 20 tons per part
Chemical corrosion resistance	-Withstand the seawater corrosion (>35 ppt)
Operational Temperature	2°C
HID subsystem for the lower part of RTC	-Produce 300W of heating power at least.
Structural loads	-Each part has to withstand the sea currents' dynamic pressure (0.1 m/s to 0.7 m/s). -Qualification load: Burst pressure of 5 bars. -Local Buckling due to SR mass. Qualification load >510 kN -Temperature increase: From 2°C to 27°C (RTC ₁ only)

Stiffening Rings Structural Requirements

The stiffening rings connect both, the RTC_u and the RTC_l parts; transfer the Riser Tube's lateral loads to the Mooring lines (Figure 9, Table 3)

Table 3: MIFIS Stiffening Ring (SR) Design Structural Requirements.

SR Structural Requirements	
Dimensions	External Diameter:3 meters Internal Diameters: 2 meters
Material properties	Aluminum or GFRP

PULMONOLOGY

Mass in air (tons)	Not exceeding 750 kg per SR
Chemical corrosion resistance	- seawater (>35 ppt) - crude oil corrosion and toxicity
Operational Temperature	5 °C
Structural loads	lateral loads equal with 15kN

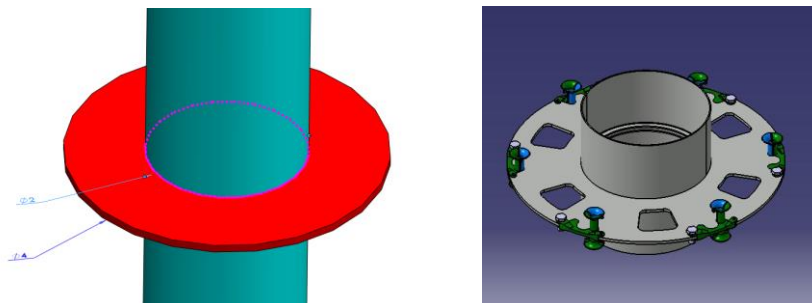

Figure 9: MIFIS Concept conceptual Stiffening Ring part (left) and DIFIS System detailed design part (right).

These components are similar to DIFIS's SR.

Heat Induced Device Structural Requirements

The HID is an optional device for the MIFIS System (Figure 10). It protects the RTCI walls from plug formation (Bai, 2010). It is based on an electric circuit with subsea Batteries (DC current) and heating elements (Subtech, 2009). The produced heat increases the RTC wall temperature, transferring heat energy to the seawater inside the riser. Following this procedure, the water temperature increases and can lead to hydrate decomposition near the walls. This process secures the continuous upward flow in the pipeline. The Structural Requirements and the main design guidelines are summarized in Table 4:

Table 4: Heat inhibitor device (HID) Design Structural Requirements.

HID Structural Requirements	
Dimensions (mm)	400 x 150 x 150
Material properties	Steel structure
Mass in air (tons)	Max 20 kg per pack
Chemical corrosion resistance	- seawater corrosion (>35 ppt) - the crude oil corrosion and toxicity
Operational Temperature	At least 5 °C
Structural loads	Hydrostatic pressure of 2000 meters (200 bars)
Heated Water film thickness	-At least 10 mm The wall temperature has to be increased from 2°C to 27°C.

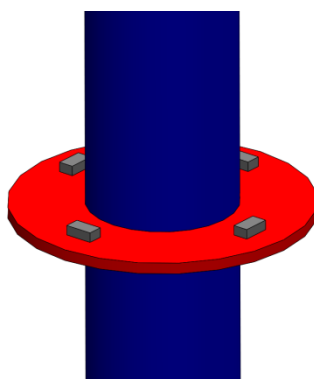

Figure 10: Heat/Inhibitor Device Location on the SR structure

The HID units are included to the MIFIS System as additional components for specific use and are supplied by EU manufacturers.

Pressure-Gravitational Buffer Bell Separator Structural Requirements

The PG-BBS functions (Mazarakos and Kostopoulos Part 3, 2015) are based on the gas pressure and the stratified gravitational separation. The advantage of the PG-BBS is that can operate at open bottom sea conditions under the hydrostatic depth pressure. It is an innovative and patented structure. The PG-BBS is consisted of 7 main parts, as are presented in Figure 11:

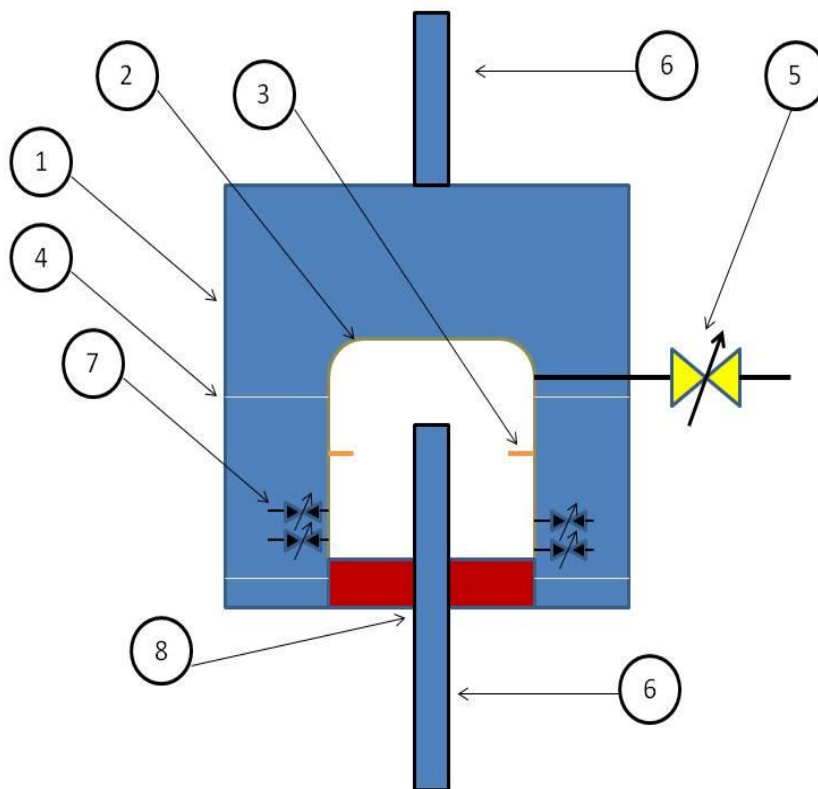

Figure 11: Cross-Section of the PG-BBS with the main parts

The main parts are:

- 1) The external hull (1) where the seawater and the separated oil from the mixture are temporary stored in order to pass through the upper riser tube (6)
- 2) The chamber (2) where the mixture is separated.
- 3) The End Stop links (3) that control the maximum position that can be reached by the piston ram (8). Similar end stops there are at the lower part of the chamber controlling the minimum position of the piston ram.
- 4) The Connection Rings which are structural parts and connect the external hull with the chamber (4). They also secure that the PG-BBS can act as continuous structure.
- 5) The Gas Regulator Valve (5), which controls the gas release from the chamber to a storing unit (FPSO, DP platform etc) through an umbilical flexible riser tube.
- 6) The Riser Tube Column (RTC) (6) where: a) the oil/water separated mixture (upper RTC) is guided to the Buffer Bell and b) the blow-out mixture (lower RTC) is gathered and guided to the PG-BBS. The lower RTC is supported inside the Chamber using the RTC support.
- 7) The Oil Regulator Valve (7), which controls the oil release from the chamber to the seawater internally to the PG-BBS (between the external hull and the chamber).
- 8) The Ram piston (8) which controls the volume that is occupied by seawater and oil using the gas pressure.

PULMONOLOGY

The structural requirements and the design guidelines for PG-BBS (Figure 12) are presented on Table 5:

PG-BBS Structural Requirements	
Maximum PG-BBS volume (m ³)	5800
Dimensions for External Hull	Diameter: 18 meters Length: 40 meters
Dimensions for Chamber	Diameter: 10 meters Length: 22 meters Volume: 950 m ³
Connecting Rings	-Lightweight structure -Connecting and Supporting the external hull with chamber
End Stops	-Light Weight structure -Securing the Ram-Piston max/min position
Ram-Piston	-Light Weight structure -Assembled with RTC
RTC Support	-Light Weight structure -Assembled with RTC
Maximum floater's buoyancy (tons)	3000
Material properties	Steel structure or GFRP
Mass in air (tons)	Not exceeding 2200 tons
Chemical corrosion resistance	- seawater corrosion (>35 ppt) -crude oil corrosion and toxicity
Maximum depth position (m)	300 meters below the sea surface
Operational Temperature	5-20°C
Structural loads	-Floater: Hydrostatic pressure of 300 meters (30 bars) -External Hull: Dynamic pressure due to sea currents velocity (0.6 m/s). - Chamber: a) Differential pressure of 5 bars due to separation. b) Fatigue load due to alternative filling/offloading gas procedure

Table 1: Pressure-Gravitational Buffer Bell Separator (PG-BBS) Design Structural Requirements.

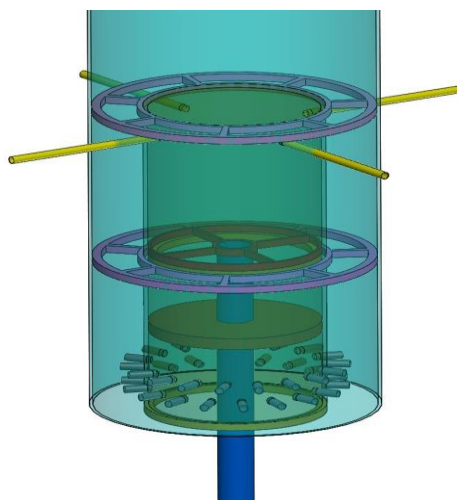

Figure 12: 3D view of the PG-BBS in operation. The ram-piston (brown) is moving up while the gas is already escaped through the Regulator valves (yellow) and the oil/water mixture passes through the oil regulator valves (grey).

Dome Interface Unit Structural Requirements

The DIU is a critical part for the MIFIS system's structural integrity. It connects the lower part of the RTC with the Dome and delivers the massive bending moment from the BB, LGS and the RT columns. The Dome Interface Unit (Figure 13) also supports the mooring lines which run through the RT columns, at the SRs' periphery. It is made of metallic or composite/ sandwich structure following the light structures design theory. The Structural Requirements are summarized in Table 6.

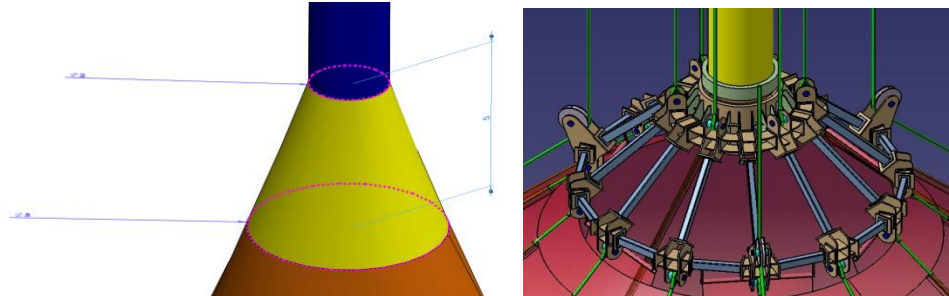

Figure 13: MIFIS Dome Interface Unit dimensions at Conceptual view (left) and DIFIS DIU detail design view (right)

DIU Structural Requirements	
Material properties	Steel structure or Composite sandwich structure (High strength Glass Fibers with balsa/foam/honeycomb core)
Dimensions (m)	-Small base diameter: 2m -Large base diameter: 22 m -Height : 10 m
Maximum Structural loads	-Withstand 1880 kN at each connection with the mooring lines. -Withstand 940 kNm of bending moment at the RTC connection point.
Mass in air (tons)	Not exceeding 100 tons
Chemical corrosion resistance	-Seawater corrosion (>35 ppt) -Crude oil toxicity and corrosion
Operational Temperature	2°C

Table 2: Dome Interface Unit (DIU) Design Structural Requirements.

The MIFIS's Dome Interface Unit follows the same methodology as the DIFIS System. The structural requirements are more demanding than the DIFIS's DIU.

Dome Structural Requirements

The Dome covers the well's blow out and guides the flow mixture to the RTC passing through the DIU. The Dome gathers the blow out mixture, limits the uncontrollable leakage and dispersion to the sea. The blow out mixture (oil/gas) can be dispersed to the seawater by the sea currents (Figure 14). The Dome's specifications are presented in the Table 7.

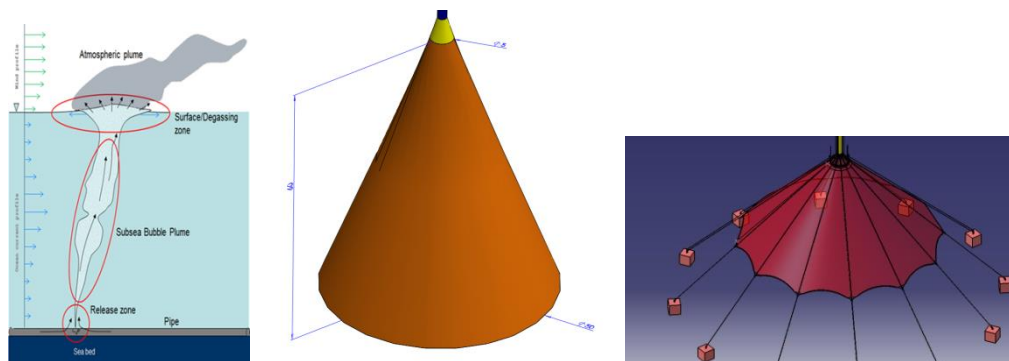

Figure 14: Blow out mixture dispersion without Dome due to sea currents motion (left), MIFIS's Dome conceptual view (centre) and DIFIS's Dome detail view (right)

PULMONOLOGY

Dome Structural Requirements	
Material properties	Lightweight, flexible fabric cloth
Dimensions (m)	Covering the blow out well diameter -Small base diameter: 22m -Large base diameter: 50 m -Height : 50 m
Maximum Structural loads	-Normal operational scenario's pressure on dome's surface : $\Delta P = + 5.14$ Pa (outside) $\Delta P = - 25.7$ Pa (inside) -Survival scenario, RTC ₁ blockage: $\Delta P = - 100$ Pa (inside)
Mass in air (tons)	Not exceeding 1.3 tons
Chemical corrosion resistance	-Seawater corrosion (>35 ppt) -Crude oil toxicity and corrosion
Operational Temperature	2°C

Table 3: MIFIS's Dome (D) Design Structural Requirements.

The MIFIS's Dome is smaller than the DIFIS's Dome. As the DIFIS's dome was large in order to cover the half of VLCC tanker, this priority was changed to the MIFIS conceptual approach. The oil/gas well diameter has lower diameter, thus the Dome's diameter was reduced from 100m to 50 m.

Mooring/Anchoring System Structural Requirements

The mooring system is the component which transfers all the inertia and hydrodynamic loads from BB, RTC, LGS/PG-BBS etc. The mooring lines' strength and the stiffness affect the deformations and the operational limits of the MIFIS System (Cortland, 2005; U.S Navy Salvage Handbook, 2000). The anchoring system transfers the loads from the mooring system to the seabed (Table 8).

Mooring/Anchoring System Structural Requirements	
Material properties	Mooring: Light weight structure, Density= 1500 kg/m ³
	Anchor: Alumina Cement , Density 2300 kg/m ³
Maximum Dimensions (m)	Mooring: Diameter 96 mm
	Anchor: 50x50x 12 meters
Structural loads	Mooring: Withstand 200 tons of pretention force at least. Residual Strength: 460 tons
	Anchor: Vertical force: 1800 kN Lateral force: 200 kN Axial force: 800 kN
Mass in air (tons)	Mooring: Max 8.5 kg/m
	Anchor: 360 tons per anchor at least.
Chemical corrosion resistance	-Seawater corrosion (>35 ppt) -Crude oil toxicity and corrosion
Operational Temperature	2°C

Table 4: Mooring/Anchoring System Structural Requirements.

The selection of the deadweight anchors is based on the easy deployment procedure and the mechanical reliability. Following the DIFIS System design procedure, the dimensions of the mooring/anchoring system was estimated for the MIFIS System.

MIFIS CONCEPT FEASIBILITY STUDY

Feasibility study is an assessment of the practicality of a proposed project. A feasibility study aims to objectively and rationally uncover the strengths and weaknesses of the proposed venture, opportunities and threats present in the environment, the resources required to carry through, and ultimately the prospects for success.

A feasibility study evaluates the project's potential for success; therefore, perceived objectivity is an important factor in the credibility of the study for potential investors and lending institutions. It must therefore be conducted with an objective, unbiased approach to provide information upon which decisions can be based. At this work only the Technical Feasibility study is presented.

Technical feasibility

This assessment is based on an outline design of system requirements, to determine whether a company has the technical expertise to handle completion of the project. The technical feasibility study has to include:

- A brief description to assess more possible factors which could affect the study: This part was presented in operational environment description.
- The part of the business being examined: This part was presented in MIFIS concept-a modified DIFIS System section.
- The possible solutions to the problem: This part was further analyzed on MIFIS components' structural requirements/specifications and Design Guidelines.
- The human and economic factor: These factors were presented in current's work introduction.
- Additional acceptance criteria based on specific data for the system's functions/operations: This part is presented below using the Weight/balance stability analysis.

Generally, the technical feasibility assessment is focused on gaining an understanding of technical resources and their applicability to the expected needs of the proposed system. It is an evaluation of the hardware and software and how it meets the need of the proposed system. The additional acceptance criteria are based on the necessary installation equipment and the operational sustainability of MIFIS after the in site installation using the Weight/Balance stability criterion.

The subsea/offshore installation involves a large amount of ships, barges, ROVs and platforms (Gerwick, 2000). The installation map with the necessary offshore equipment is presented in Figure 15. The maximum capacity (deadweight in tonnes) of each vessel and their dimensions are the most important factors for the selection (DIFIS, 2006).



Figure 15: Necessary installation equipment Map for the MIFIS Concept.

The Weight/Buoyancy stability balance

The Weight/Buoyancy Balance is critical for the MIFIS stability on the seabed. The equilibrium at the vertical axis (along the RTC) has to be investigated (Figure 16).

PULMONOLOGY

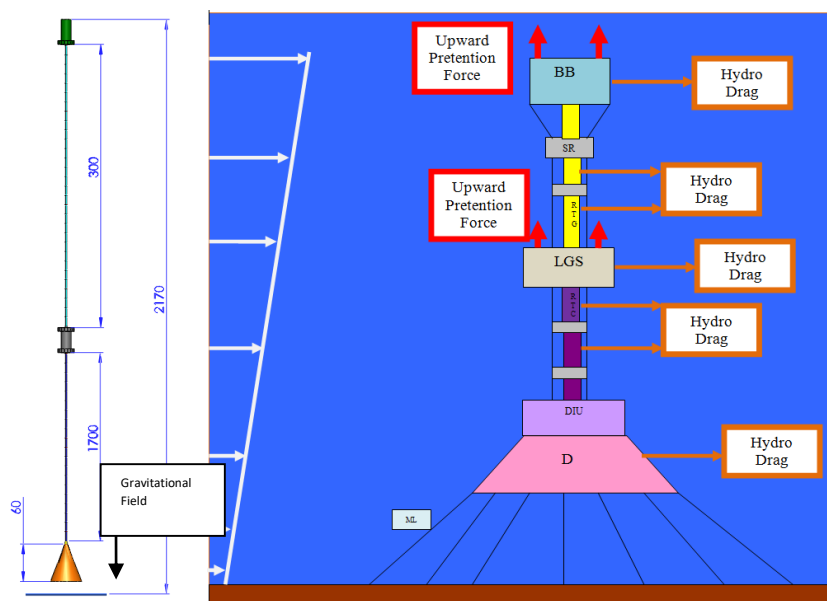

Figure 16: MIFIS Concept main dimensions for total depth 2200m from sea surface

For the equilibrium: $\text{Net Force} = \text{Buoyancy} - \text{Weight} > 0$ for stable condition. In Table 9, the vertical stability of MIFIS concept is presented following the structural requirements.

Component	Number of parts	Mass per part (tons)	Component mass (tons)	Component Buoyancy (tons)	Net force (tons)
Buffer Bell	1	900	900	3000	2100
Stiffening Rings	133	0.75	99.75	(X)	-99.75
Buffer Bell Separator	1	2200	2200	3000	800
Heat Inhibitor Device (optional)	798	0.02	15.96	(X)	-15.96
Riser Tube Column	136	18	2448	1045.476	-1403
Dome Interface Unit	1	100	100	(X)	-100

Dome	1	1.3	1.3	9.8	8.5
Mooring lines at the periphery of RT	6	16.94	101.64	89.29	-12.35
Mooring lines at the periphery of Dome	12	4.235	50.82	44.64	-6.18
Net upward force (sum) in tons					1270.76

Table 5: Conceptual estimation of the Net buoyancy force

The necessary upward net force is close to the DIFIS's net tension force (1000 tons).

The MIFIS concept's axial forces on the mooring system are compared with the mooring forces in DIFIS project following the same methodology. The results are presented in Table 10:

System	Axial Force per Mooring line (tons) on anchor (Net upward Force 1000 tons)
DIFIS	179.0
MIFIS	195.0
System	Axial Force per Mooring line (tons) on anchor (Net upward Force 1270 tons)
MIFIS	218.0

Table 6: Mooring force comparison for MIFIS and DIFIS System.

The mooring force difference between the MIFIS and DIFIS system is close to 9% for the same pretention load. The maximum load on the mooring line is 218 tons for the proposed pretention load (1270 tons). This load is lower than the mooring line's maximum axial force (460 tons).

CONCLUSIONS

In the current work, the principal investigation (operational environment, components' functions and technical description and structural requirements) were presented. As part of the MIFIS PoC Feasibility study this investigation was also taken into the installation equipment and acceptance criteria. The investigation concludes that the proposed MIFIS concept can operate as a modification of the DIFIS System. Additional components have to be developed such as Press-Gravitational Buffer Bell Separator for efficient blow-out recovery. The main components of DIFIS System can be upgraded to the MIFIS components. The Feasibility Study for the MIFIS concept outlines that:

- For each PG-BBS, a floater similar to DIFIS Buffer Bell is necessary to produce upward net force on the mooring system, keeping it fully tensioned.
- The PG-BBS has to be placed at a maximum depth 300m below the sea surface.
- The PG-BBS (1270 tons pretention) increases the axial load on each mooring line close to 22%.
- For higher flow rates (> 40 m³/h), more than a PG-BBS can be assembled on Riser Tube column. The maximum number of PG-BBS components is limited to three (3) with safety factor 1.5.

ACKNOWLEDGEMENTS

The authors wish to acknowledge the role of Dr. F. Andritsos as inventor of the DIFIS/MIFIS System and the opportunity to participate in preliminary feasibility study of this innovative structure for blow-out recovery. The authors also wish to acknowledge the work of Andreas Ampatzoglou, Mechanical Engineer/PhD candidate at Applied Mechanics Laboratory, which performed in 3D CAD visualization of PG-BBS structure.

REFERENCES

- [1] Andritsos F. and Cozijn H. (2011), "An innovative oil pollution containment method for ship wrecks proposed for offshore-well blow outs", Proceedings of the ASME 2011 30th International Conference on Ocean, Offshore and Arctic Engineering OMAE 2011, Rotterdam, Netherlands.
- [2] Bai Y. and Bai Q. (2010), Handbook of Subsea Engineering, Elsevier Inc.
- [3] Bollavaram P. (2002), Hydrate Plug Dissociation in Pipelines by Pressure Reduction: Experiment and Modeling, PhD Thesis, Colorado, USA.

- [4] Cortland (2005), “Vectran 12 Strand & 12x12”, Technical Sheet available at: <http://www.cortlandcompany.com/sites/default/files/downloads/media/product-data-sheets-vectran-12-strand.pdf>
- [5] Demirbas, A. (2010), Methane Gas Hydrate, Springer-Verlag London Limited.
- [6] Devinder M., Taylor E.C. and Mansoori Ali G., (2007), “An introduction to natural gas hydrate/clathrate: The major organic carbon reserve of the Earth”, Journal of Petroleum Science and Engineering Vol. 56, pp 1–8.
- [7] DIFIS Project FP6-516360 (2006), Report on Deployment & Recovery Procedure.
- [8] Gerwick C.B. Jr (2000), Construction of Marine and Offshore Structures ,CRC Press LLC.
- [9] Hardage B. and Roberts H. (2006), “Gas hydrate in the Gulf of Mexico”, The Leading Edge, pp 566-571.
- [10] Holand,P. (1997), Offshore Blowouts- Causes and Control , Gulf Publishing Company, Houston, Texas
- [11] Huo H,Liu Y.,Zheng Z., Zhao J.,Jin C. et al. (2011) , “Mechanical and thermal properties of methane clathrate hydrates as an alternative energy resource”, Journal Of Renewable and Sustainable Energy, Vol. 3 .
- [12]Lundgaard L. and Mollerup J. (1992), “Calculation of Phase Diagrams of Gas-Hydrates”, Elsevier Science Publishers B.V.,Fluid Phase Equilibria, Vol. 76, pp 141-149.
- [13]Mazarakos E.D., Andritsos F. and Kostopoulos V. (2012), “Recovery of Oil-Pollutant from Shipwrecks: DIFIS Project”, International Journal of Structural Integrity, Vol. 3, pp.285 – 319
- [14]Mazarakos E.D. (2012), Design, analysis and Optimization of a Subsea Structure for the oil Recovery from shipwrecks, the DIFIS Project, Nemertes: PhD Thesis, Patras, Hellas/Greece
- [15]Mazarakos E.D., Kostopoulos V. (2015), Part 1: Deliverable on Theoretical Framing, Project MIFIS: Proof of Concept Consultancy Services,Patras, Hellas/Greece.
- [16]Mazarakos E.D., Kostopoulos V. (2015), Part 2: Deliverable on Calculations/Simulations Results Overview, Project MIFIS: Proof of Concept Consultancy Services, Patras, Hellas/Greece.
- [17]Mazarakos E.D., Kostopoulos V. (2015), Part 3: Deliverable on Structural Requirements, Project MIFIS: Proof of Concept Consultancy Services, Patras, Hellas/Greece.
- [18] Sloan D. and Koh A.C. (2008), Clathrates Hydrates of Natural Gases, CRC Press Taylor and Francis Group, Third Edition.
- [19]SubCtech Subsea Technologies (2005), “Li-Ion Powerpack” available at: <http://www.rsaqua.co.uk/uploads/pdfs/Products/SubCtech/Li-Ion/Brochure PowerPack 1600Wh.pdf>
- [20]U.S Navy Salvage Engineer’s Handbook (2000), Salvage Engineering Volume 1.
- [21]Wikipedia The free Encyclopedia, (2010), “Deepwater horizon” available at: http://en.wikipedia.org/wiki/Deepwater_Horizon